

# Study Regarding the Compressive Properties of Glass Fiber Reinforced Composites

PAULINA SPANU\*, CATALIN GHEORGHE AMZA, BOGDAN FELICIAN ABAZA

University Politehnca of Bucharest, 313 Spl. Independentei, 060042, Bucharest, Romania

*Compressive strength of the polymeric composites is an important data for design of composite structures and therefore a depth study of this mechanical property is imperative. The mechanical properties of the polymer composites vary in the very large ranges according to the characteristics of the constituents, to their proportions and many other factors. Compressive property and failure mechanism of polymer composite materials reinforced with glass fiber were investigated in this paper. The experimental data for the studied materials were included the compressive strength, strain, poisson's ratio and modulus. Some of these experimental values could be affected by aberrant errors. This paper also presents an application that removes the experimental data affected by gross errors from the sample of numerical values. The elimination of experimental data affected by gross errors is based on Chauvenet criterion.*

*Keywords: compressive strength, failure mechanism, LabVIEW, gross errors*

Polymer composite materials are attractive for industrial applications, especially due to their mechanical properties. The properties of the composite materials are influenced by many factors such as: the characteristics of the constituent materials, manufacturing technology, the percentages of the constituent materials, the dimensions and the arrangement of the reinforcement elements into the matrix, the fiber-matrix interface properties, the degree of humidity of the material [1, 2]. The heterogeneity of composite and defects such as microcracks and voids, determined by the manufacturing process, influence significant the compressive strength of the composite more than any other mechanical properties. The glass fiber polymer composites are most affected by environmental humidity because both constituent materials are susceptible to water [3, 4].

The glass fiber polymer composites properties vary from point to point of material and from one direction to another [5]. Different values of compressive strength could be obtained for the samples taken from the same raw material. The main reasons are the uneven distribution of reinforcement in the matrix, voids and the impurities.

Many failure modes have been observed during the compression tests of the composite materials reinforced with the short glass fibers [6]. The predominant compression failure modes are determined by the constituent properties, fibers orientation, method of load introduction, voids and stress concentrations. These failure modes generally include the microbuckling. Microbuckling is the buckling of fibers within the matrix and it can occur out of phase or in phase. The buckling occurred out of phase is named extensional microbuckling. If the buckling happens in phase is named shear microbuckling.

The compressive response of the composite materials random reinforced with the short glass fibers has been a theme of research in recent years. Considering the numerous factors that influence the experimental results, a thorough research of the compressive response without the experimental data affected by gross errors is required.

## Experimental part

The constituents of the composite material used in the experimental research are Aropol S 599 polyester resin and

EC12-2400-P1800(65) glass. The glass fibers with an effective diameter of  $12\mu\text{m}$  and fineness = 2400 [tex] were random distributed into the matrix in 40% proportion.

The shapes and dimensions of specimens were based on the SR EN ISO 604: 2000 standard [7]. This standard sets the parameters for the specimens made from glass fiber reinforced polymeric composite. The specimens used for the compression testing are shown in figure 1.

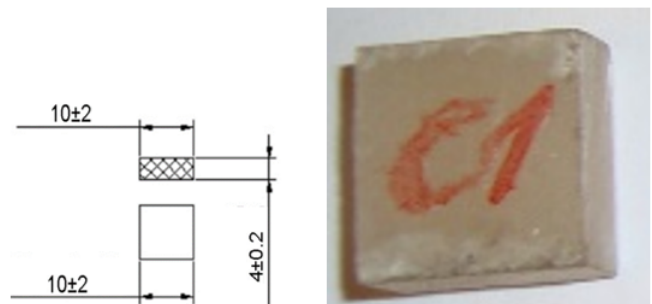

Fig. 1. Polymer composite specimen

The specimens taken from the studied composite material with scratches, cavities, shrinkage, ridge or other imperfections that would have a negative influence on the experimental results were eliminated from the sample.

The dimensions of the specimens selected to perform the compression test were measured in three points of each specimen and then, the average cross-sectional area value was calculated. Specimens whose dimensions did not fit within the prescribed tolerances were removed from the tested sample. Dimensions of the specimens subjected to the compression test are presented in table 1.

Measurements of compressive strength are affected by the specific test method and conditions of measurement. Therefore, the compression testing was conducted according to the SR EN ISO 604:2004 Standard. According to this standard, the method of determining the compression properties consists of compressing a specimen along its main axis with a constant speed until the specimen is broken or until the load or decrement in length has reached a predetermined value. The composite samples were subjected to mechanical testing of compressive strength on a LFV 25 HH WALTER-BAI universal testing machine with a load cell of 5 kN and speed

\* email: pauspa16@yahoo.com; Phone: 0766782100

**Table 1**  
DIMENSIONS OF TESTED SPECIMENS

Specimen	l [mm]	b [mm]	h [mm]
C1	9.82	10.17	4.1
C2	9.89	9.95	4.16
C3	9.94	10.16	3.87
C4	9.97	10.04	4.09
C5	10.01	10.09	4.16
C6	10.12	9.99	3.99
C7	9.92	9.98	4.08
C8	9.86	10.07	4.17
C9	10.09	10,09	3.92
C10	9.91	10	3.89
C11	9.96	9.87	4.09
C12	10.19	9.97	4.18

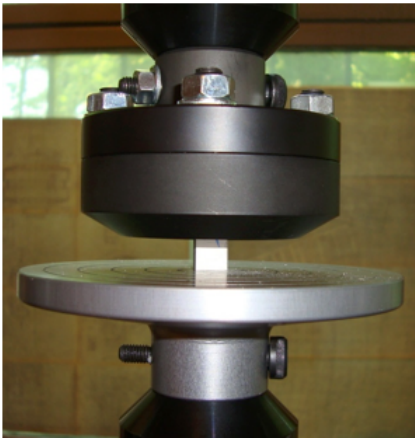

Fig. 2. The specimen during compression test

1 mm/min for measuring modules and 5 mm/min for compressive strength measurement. The figure 2 shows the specimen during compression test using the universal machine LFV 25 HH WALTER-BAI.

The following compressive properties were measured:  
 - ultimate compressive strength - is the value of uniaxial compressive stress reached when the material fails completely;  
 - ultimate compressive strain - represents the decrease of the reference length on the initial length unit of the reference length, reached when the material fails completely;  
 - Young's Modulus for compression.  
 Compressive strength (MPa) is given by the following formula (1):

$$\sigma = \frac{F}{A} \quad (1)$$

where, F = Load applied [N], A = Cross section area [mm<sup>2</sup>].  
 Compressive strain is given by the formula (2):

$$\varepsilon = \frac{l - l_0}{l_0} \quad (2)$$

where l = current specimen length [mm] and l<sub>0</sub> = original specimen length [mm].

### Results and discussions

Twelve samples were used for the compression test. For the studied materials it was observed that the damage of the specimens was caused by interlaminar failure and less due to the breakage of the glass fibers as is shown in the figure 3. The shear microbuckling occurred in phase was the result of the heterogeneity of material, microcracks and voids. These defects were manly determined by the

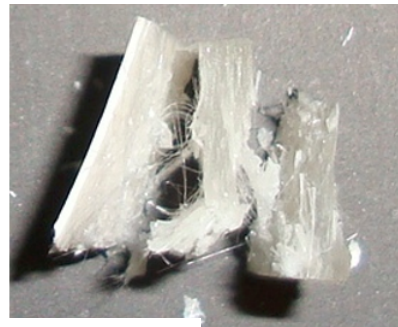

Fig. 3. The failure mode of the sample

Description	Result
Width x Thickness WxT	10.19 x 4.18 mm
Startsection S <sub>0</sub>	42.59 mm <sup>2</sup>
E-Modulus E	4.23 GPa
Load max F <sub>m</sub>	7.74 kN
Deformation at F <sub>max</sub> Agt	0.38 %
Elongation A	0.45 %
Tensile strength R <sub>m</sub>	181.73 MPa

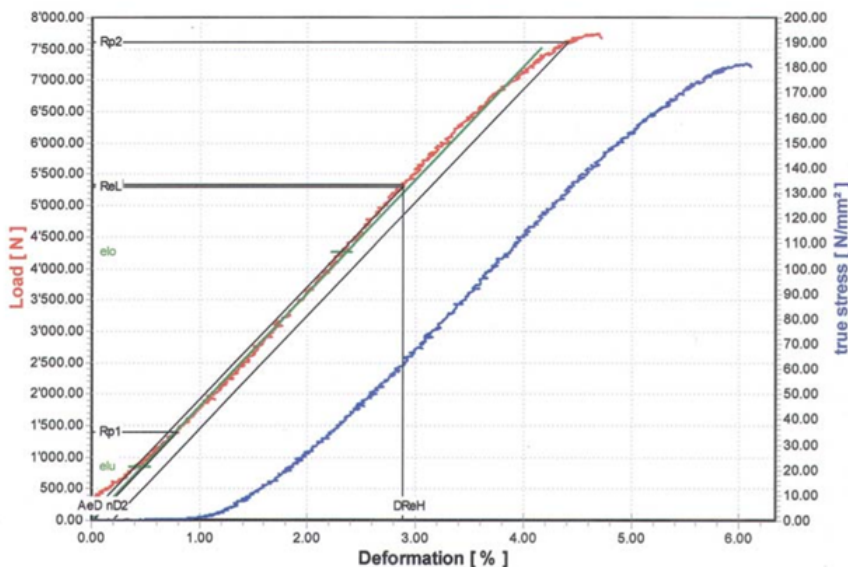

Fig. 4. The compression test report

manufacturing process of the composite. The composite was manufactured by spray-forming in an open mold and the voids were manual eliminated. Another significant factor was the poor interfacial link to the fiber-matrix generated by the coupling agent used in the composite fabrication. When the fibre/matrix bonding is poor, failure occurs by delamination and global delamination buckling.

The test report that includes a stress-strain curve is plotted by the *WALTER-BAI* instrument and looks similar to the figure 4.

As it can see in the above picture, in the compression test the initial deformation is linear elastic. This linear region terminates at what is known as the yield point. Above this point, there is not a plastically region where the material does not return to its original length once the load is removed. The compressive strength data for the E-glass composite with the Vf 0.40 fiber volume fraction are presented in table 2.

**Table 2**  
THE EXPERIMENTAL DATA

Specimen	Compressive strength [MPa]	Modulus [GPa]
C1	168.72	4.07
C2	146.23	4.00
C3	177.58	4.04
C4	181.73	4.23
C5	180.29	3.80
C6	178.86	4.02
C7	182.77	4.09
C8	173.14	4.06
C9	184.9	4.13
C10	90.94	3.89
C11	141.23	3.91
C12	85.76	2.97

The experimental results belong to the range described by the other researchers for the polymer composite randomly reinforced with short glass fiber. These experimental data are specific to composites which are manufactured using the spray forming into an open mold. Some of the experimental values could be affected by gross errors. The elimination of experimental data affected by errors can be realized using a dedicated software application developed as a virtual instrument in LabVIEW - graphical programming environment. The algorithm of

virtual instrument was based on Chauvenet criterion to removes the experimental data affected by gross errors from the sample of numerical values.

According with Chauvenet criterion, an array of experimentally data may contain values affected by gross errors [8]. A numerical value  $x_i$  of an array is affected by errors if the condition regulated by the formula (3) [8] is fulfilled.

$$|x_i - \bar{x}| > z * \sigma \quad (3)$$

where:  $\bar{x}$  - is the average form the numeric values in the array;

$\sigma$  - standard deviation calculated from the values in the array;

$z$  - the values calculated with the formula (4).

$$z = \frac{0.453 - 0.862 * a}{1 - 3.604 * a + 3.213 * a^2} \quad (4)$$

Where:  $a$  - represents the values calculated with the formula (5).

$$a = \frac{2 + n - 1}{4 + n} \quad (5)$$

and,  $n$  is the number of experimental values in the array.

By performing the calculations according to the *Chauvenet* criterion [8], if one of the determined experimentally numerical values is affected by gross errors, the respective value is removed from the sample of the numerical values. After this value is removed, the mean and standard deviation for the remaining string values is recalculated and the condition (3) is resumed, the algorithm being applied until condition (3) is no longer checked for the extreme values of the sample. The extreme values were obtained for the samples that were taken from the composite material with a large area of defects such as the uneven distribution of reinforcement in the matrix, voids and the impurities.

The virtual instrument also calculates the mean of the values, standard deviation and variance as it can see on the front panel of the virtual instrument (fig. 5).

On the block diagram of the virtual instrument was described the algorithm to perform the calculations according to the *Chauvenet* criterion (fig. 6).

By using this programming approach, this software application has the potential to be declared as sub-VI [9], which is a subroutine and it allows further developments

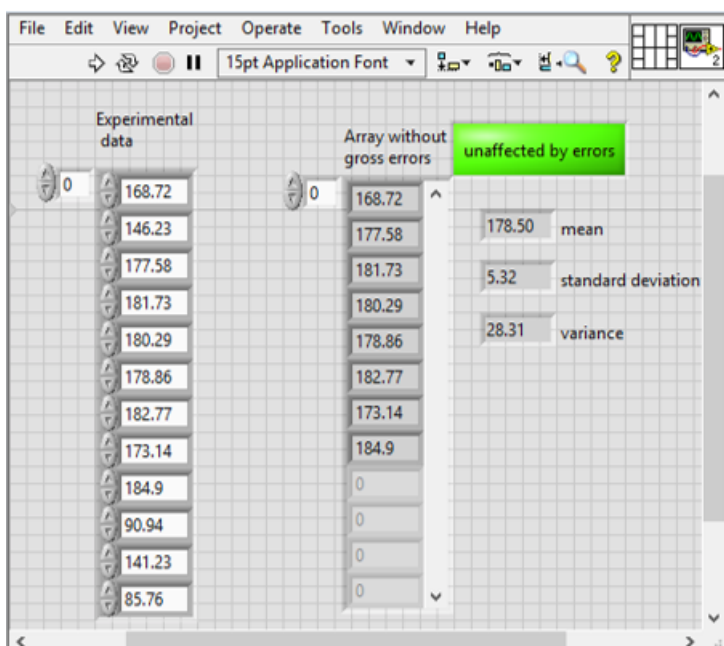

Fig. 5. The front panel of the virtual instrument

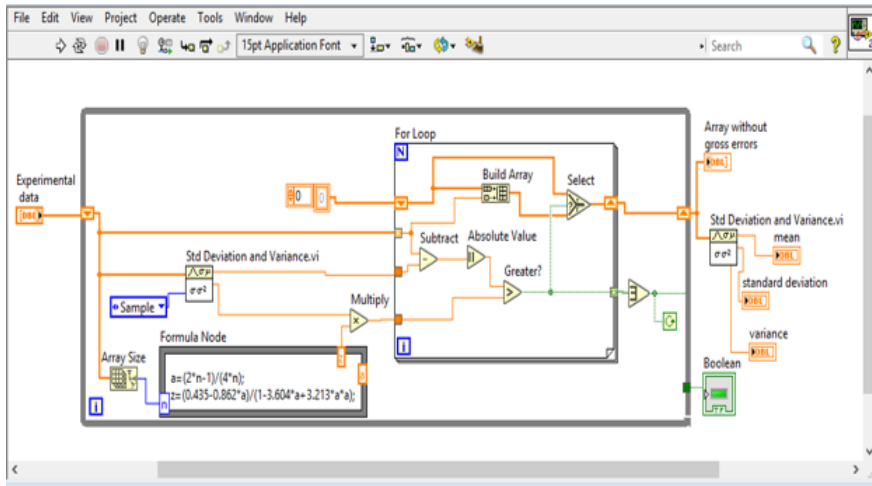

Fig. 6. The block diagram of the virtual instrument

and integration in more complex applications which can be automatically supplied with experimental data without gross errors.

### Conclusions

The composite materials studied are characterized by a high degree of inhomogeneity and large variations in mechanical properties even for specimens taken from the same material. Large variations in compressive strength have been identified, mainly due to the uneven distribution of reinforcement material in the matrix, voids and the poor bond fiber-matrix. These defects have also conducted to the shear microbuckling mechanism of the tested specimens.

It can be concluded, that for important applications in which these materials are subjected to compression, another composite manufacturing process must be adopted. This was in fact, the major reason for the large field of distribution of recorded values. To fully characterize the composite material studied, a tool was needed to remove the values affected by gross errors from the experimental sample. Without using this tool, the calculation would have been laborious and repetitive.

In this paper it was also presented a dedicated software application developed as a virtual instrument in the LabVIEW graphical programming environment [9]. This application was proved to be useful for processing the raw experimental data and to be able to eliminate gross errors. The application has the real potential of integration such a sub-VI in another more complex applications.

### References

- MARINESCU, M., BUTU, L., BORDA, C., ARSENE, D., BUTU, M., Comparative Study of Tensile Behaviour for Layered Polymeric Composite Materials, *Mat. Plast.*, **55**, no. 3, 2018, p. 279 - 285
- BOLCU, D., STANESCU, M.M., CIUCA, I., DUMITRU, S., SAVA, M., The Non-uniformity from the Composite Materials Reinforced with Fiber Glass Fabric, *Mat. Plast.*, **51**, no. 1, 2014, p. 97-100
- AHMED, N., MUSTAFA, M.S., A study on tensile and compressive strength of hybrid polymer composite materials (e glass fibre-carbon fibre-graphite particulate) with epoxy resin 5052 by varying its thickness, *International Journal of Mechanical Engineering and Technology (IJMET)*, Volume 6, Issue 4, April (2015), pp. 17-26
- HADAR, A., CONSTANTINESCU, I. N., JIGA, G., IONESCU, D.S., Some Local Problems in Laminated Composite Structures, *Mat. Plast.*, **44**, no. 4, 2007, p. 354-360
- ZGIRIAN, G., DEMETRESCU, I., GHEORGHIU, H., IOVU, H., HADAR, A., ATANASIU, C., *Rev. Chim. (Bucharest)*, **56**, no. 7, 2005, p. 757-761
- DRAGHICI, S., PARAUSANU, I., BACIU, F., PETRESCU, H.A., HADAR, A., PASTRAMA, S.D., A Comparative Experimental - Numerical Analysis on the Vibration Behaviour of a Composite Satellite Subset, *Mat. Plast.*, **53**, no. 4, 2016, p. 585-589
- \*\*\* SR EN ISO 604/1996, Materiale plastice. Determinarea proprietatilor de compresiune
- SPANU, P., SAVU, T., ABAZA, B., *Indrumar de laborator bilingv (roman - englez) Programarea calculatoarelor*, Editura PRINTECH, 2018
- ABAZA, B., SAVU, T., SPANU, P., *Algoritmi, Indrumar de laborator*, Editura PRINTECH, 2014

Manuscript received:23.08.2018